

MODELING FINITE PRECISION LMS BEHAVIOR USING MARKOV CHAINS

Yasmín Montenegro¹, José C.M. Bermudez² and Vítor H. Nascimento³.

¹Dep. of Electrical Engineering, University of Antofagasta, Antofagasta - Chile

²Dep. of Electrical Engineering, Federal University of Santa Catarina Florianópolis - SC - Brazil

³Dep. of Electronic Systems Engineering, University of São Paulo, São Paulo - SP - Brazil

E-mails: yasmin@eel.ufsc.br, j.bermudez@ieee.org, vitor@lps.usp.br

ABSTRACT

We propose a new model for the behavior of the Least Mean Square (LMS) algorithm when implemented in finite precision. We model the adaptive filter coefficients as a Markov chain and determine its transition probability matrix for the one-dimensional case. We also determine conditions to avoid the so-called stopping phenomenon. The proposed model eliminates the linearizations used in previous models, accounts for saturation effects and leads to accurate estimations of the mean-square error behavior. Monte Carlo simulation results illustrate the quality of the proposed model.

1. INTRODUCTION

The LMS (Least Mean Square) is one of the preferred algorithms for real-time adaptive system implementations because of its simplicity and robustness [1, 2]. Real-time implementations frequently use *hardware* that operates with fixed-point arithmetic. In these cases, infinite precision models become inadequate. The accumulation of quantization errors and other nonlinear effects inherent to finite precision operation can lead to behaviors that significantly deviate from theoretical predictions based on infinite precision models. Thus, it is of great interest to understand the behavior of the LMS algorithm when implemented in finite precision.

The finite precision behavior of the LMS algorithm has been studied by several authors [1]–[9]. In [3] and [4], analytical models were derived based on a linearized approximation of the quantization errors, which were modeled by additive white noise. The linearized model may adequate during the early stages of adaptation, when the error is large, and if saturation does not occur. After the initial acquisition period, the algorithm behavior can no longer be predicted by a linear model [8]. In [6]–[9], nonlinear models were derived which incorporate the nonlinear nature of the quantization in the weight update equation, leading to more accurate predictions of the algorithm behavior. Such models, however, still do not consider the saturation effects inherent to the finite precision processing.

In this paper we propose a new modeling technique for the behavior of the LMS algorithm. We model the adaptive weight vector as a state in a Markov chain, and study the signal statistics at a given iteration conditioned on the state at the previous iteration. We study the unidimensional case to provide insight on the new approach while keeping the mathematics simple. The new model accounts for all nonlinearities, including saturation effects.

The paper is divided in four parts. In Section 2 we define the problem and establish the notation. In Section 3 we determine the conditional probability density function (pdf) of the adaptive weight at iteration n , conditioned on the value of the weight at iteration $n - 1$. In Section 4 conditions on the step size are given. In Section

5 we use the new model to study the mean-square error behavior. Finally, we provide simulation results that verify the accuracy of the theoretical model.

2. PROBLEM DEFINITION

Consider the system identification block diagram shown in Fig. 1.

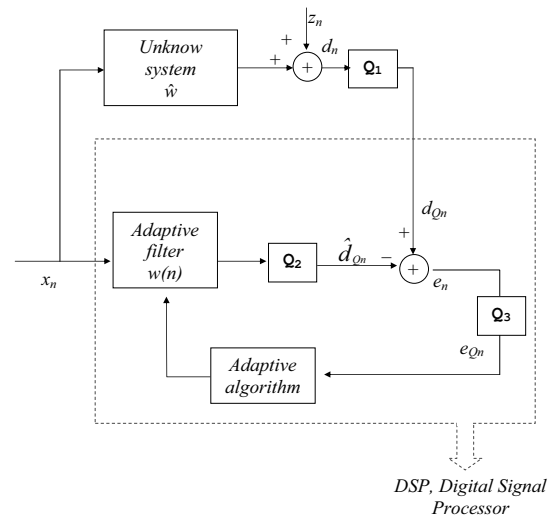

Fig. 1. System identification implemented in finite precision

In Fig. 1, x_n is the input signal, z_n is a zero-mean additive white Gaussian noise. d_n is the desired signal. \hat{w} is the unknown system response and w_n is the adaptive filter coefficient. Q_1 , Q_2 and Q_3 are identical b -bit quantizers. We assume for simplicity that all finite precision signals and coefficients are quantized with b bits. The uniform quantization step is then $\Delta = 2^{1-b}$ and the quantization limits are $[-1, 1 - \Delta]$. Fig. 2 illustrates the transfer characteristic of the quantizers for $b = 3$. The input x_n is a b -bit quantized discrete uniform random signal such that $-1 \leq x_n \leq 1 - \Delta$. This is a good model for signals in digital transmission systems. d_{Qn} is the quantized version of d_n , \hat{d}_{Qn} is the b -bit quantized adaptive filter output¹. e_{Qn} is the estimation error represented in b bits. There are $N = 2^b$ levels at the quantizer outputs.

¹In general, the output will have at least $2b$ bits before Q_2 , because of the larger accumulator word-length in digital processors.

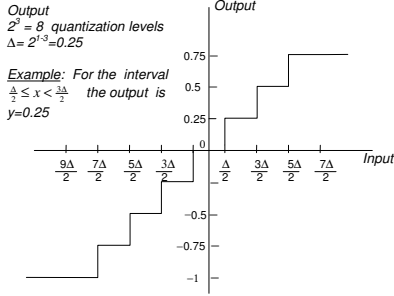

Fig. 2. Relation between input and output for a 3 bits quantizer

2.1. LMS algorithm in finite precision

The LMS weight update equation is given by

$$w_{n+1} = Q\{w_n + y_{Qn}\} \quad (1)$$

where

$$\begin{aligned} y_{Qn} &= Q\{\mu e_{Qn} x_n\} \\ e_{Qn} &= Q\{e_n\} \\ e_n &= d_{Qn} - \hat{d}_{Qn} \\ d_{Qn} &= Q\{\hat{w}x_n + z_n\} \\ \hat{d}_{Qn} &= Q\{w_n x_n\} \end{aligned} \quad (2)$$

The pdf of x_n is given by

$$f_x(x) = \frac{1}{N} \sum_{k=-2^{(b-1)}}^{k=2^{(b-1)}-1} \delta(x - k\Delta) \quad (3)$$

and the pdf of z_n is $f_z(z) = 1/\sqrt{2\pi}\sigma_z \exp(-z^2/2\sigma_z^2)$. Note that we need to define e_{Qn} and to include the quantization operation in the definition of w_{n+1} because the values of e_n and $w_n + y_{Qn}$ can exceed the saturation limits of the quantizer.

To study the dynamics of w_n , we next determine the pdf of w_{n+1} conditioned in w_n .

3. STATISTICS OF THE ADAPTIVE WEIGHTS

Given (1) and (2), the statistics of w_{n+1} depends on the statistics of y_{Qn} , e_{Qn} , d_{Qn} and \hat{d}_{Qn} . We start by studying the statistics of d_{Qn} .

3.1. Statistics of d_{Qn}

From (1), $d_{Qn} = Q\{d_n\}$ with $d_n = \hat{w}x_n + z_n$. Given \hat{w} , we define $x_{on} = \hat{w}x_n$. Then, dropping the subscript n for clarity, $\Pr\{\mathbf{x}_o = x_o\} = \Pr\{\hat{w}x = x_o\} = \Pr\{x = x_o/\hat{w}\}$ and

$$f_{\mathbf{x}_o}(x_o) = \frac{1}{N} \sum_{k=-2^{(b-1)}}^{k=2^{(b-1)}-1} \delta(x_o - k\hat{w}\Delta) \quad (4)$$

Since x_n and z_n are independent random variables, the pdf of d_n is given by convolution of the individual pdfs. Using (4) and $f_z(z)$,

$$f_d(d) = \frac{1}{N\sigma_z\sqrt{2\pi}} \sum_{k=-2^{(b-1)}}^{k=2^{(b-1)}-1} e^{-\left(\frac{d-\hat{w}k\Delta}{\sqrt{2}\sigma_z}\right)^2} \quad (5)$$

To determine the pdf of d_{Qn} , we determine the probability that d_n is in the i -th quantization interval $[d_{1i}, d_{2i}]$. Denoting this probability D_i , we have $D_i = \int_{d_{1i}}^{d_{2i}} f_d(d)dd$. Using (5) and integrating,

$$\begin{aligned} D_i &= \frac{1}{N} \sum_{k=-2^{(b-1)}}^{k=2^{(b-1)}-1} \left[\operatorname{erf}\left(\frac{d_{2i} - k\hat{w}\Delta}{\sigma_z}\right) \right. \\ &\quad \left. - \operatorname{erf}\left(\frac{d_{1i} - k\hat{w}\Delta}{\sigma_z}\right) \right] \end{aligned} \quad (6)$$

with $d_{1i} = i\Delta - 0.5\Delta$ and $d_{2i} = i\Delta + 0.5\Delta$ (notice that the lower limit of the first interval is $-\infty$, and the upper limit of the last interval is $+\infty$). The pdf is then given by:

$$f_{d_Q}(d_Q) = \sum_{i=-2^{(b-1)}}^{i=2^{(b-1)}-1} D_i \delta(d_Q - i\Delta) \quad (7)$$

We now proceed to determine the statistics of e_{Qn} .

3.2. Conditional pdf of e_{Qn}

From Fig. 1 and from (2), $e_{Qn} = Q\{d_{Qn} - \hat{d}_{Qn}\}$, with $\hat{d}_{Qn} = Q\{w_n x_n\}$. Random variables d_{Qn} and $Q\{w_n x_n\}$ depend on x_n and on w_n . Then, the conditional pdf of interest is $f_{e_Q}(e_Q|k\Delta, w_n)$.

Notice that e_n in (2) can exceed the upper and lower quantization limits. Then, we must set $e_{Qn} = -1$ for $e_n < -1$ and $e_{Qn} = 1 - \Delta$ for $e_n > (1 - \Delta)$.

We first determine the pdf of e_n . Considering that $d_{Q\max} = \hat{d}_{Q\max} = 1 - \Delta$ and $d_{Q\min} = \hat{d}_{Q\min} = -1$, we have that $\{e_n\}_{\max} = d_{Q\max} - \hat{d}_{Q\min} = 2 - \Delta$ and $\{e_n\}_{\min} = d_{Q\min} - \hat{d}_{Q\max} = -2 + \Delta$. The pdf of e_n will then be

$$f_e\{e|k\Delta, w_n\} = \sum_{k_e=-2^{b-1}}^{k_e=2^b-1} E_{k_e} \delta(e - k_e\Delta) \quad (8)$$

where E_{k_e} is the probability of occurrence of the k_e -th state of e_n . To determine E_{k_e} , let $\hat{d}_{n1} = \text{round}\{w_n k\Delta\}$ where, for $m \in \mathbb{Z}$,

$$\text{round}\{x\} = \lfloor x \rfloor = \begin{cases} m, & x < m + \frac{1}{2} \\ m + 1, & x \geq m + \frac{1}{2} \end{cases} \quad (9)$$

As \hat{d}_{n1} can exceed the quantizer limits when $w_n = -1$ and $x_n = -1$, we define $\hat{d}_n = \hat{d}_{n1} - \Delta\delta(1 - \hat{d}_{n1})$ and write $e_n = d_{Qn} - \hat{d}_n$. Then,

$$\begin{aligned} \Pr\{e_n = e|k\Delta, w_n\} &= \Pr\{d_{Qn} - \hat{d}_n|k\Delta, w_n\} = \\ &= \Pr\{d_{Qn} = e + \hat{d}_n|k\Delta, w_n\} \end{aligned} \quad (10)$$

Using $\Pr\{d_{Qn}\}$ determined from (7), we have:

$$E_{k_e} = \frac{1}{N} \left[\operatorname{erf}\left(\frac{d_{2k_e} - \hat{w}x}{\sigma_z}\right) - \operatorname{erf}\left(\frac{d_{1k_e} - \hat{w}x}{\sigma_z}\right) \right]$$

with (again, excluding the lower limit of the first interval and the upper limit of the last interval) $d_{2k_e} = d_{Q_n} + 0.5\Delta = k_e\Delta + \hat{d}_n + 0.5\Delta$ and $d_{1k_e} = d_{Q_n} - 0.5\Delta = k_e\Delta + \hat{d}_n - 0.5\Delta$.

As we obtain e_{Q_n} from e_n by saturation, the probability of occurrence of values beyond the quantization interval must be added to the probability of occurrence of the extreme values in the e_{Q_n} distribution. Then, the pdf of e_{Q_n} is given by:

$$f_{e_Q}(e_Q|k\Delta, w_n) = \sum_{k_1=2^{(b-1)}-1}^{k_1=2^{(b-1)}+1} \Pr\{e_Q = k_1\Delta|k\Delta, w_n\}\delta(e_Q - k_1\Delta) \quad (11)$$

where

$$\Pr\{e_Q = k_1\Delta|k\Delta, w_n\} = \begin{cases} \Pr\{e = k_1\Delta|k\Delta, w_n\}, & -1 < e_{Q_n} < 1 \\ \sum_{k_e=2^{b-1}-1}^{k_e=2^b-1} \Pr\{e = k_e\Delta|k\Delta, w_n\}, & e_{Q_n} = 1 - \Delta \\ \sum_{k_e=-2^{(b-1)}-1}^{k_e=-2^{(b-1)}+1} \Pr\{e = k_e\Delta|k\Delta, w_n\}, & e_{Q_n} = -1 \end{cases} \quad (12)$$

3.3. Conditional pdf of y_{Q_n}

Consider $y_n = \mu e_{Q_n} x_n$, with e_{Q_n} and x_n quantized values. Then,

$$y_n = \mu k_e \Delta k \Delta = \mu (k_e k) \Delta^2 = \mu k_y \Delta_y \quad (13)$$

where $k_y = k_e k$ and $\Delta_y = \Delta^2$.

Since $\max\{k_y\}$ occurs for $\min\{k_e\}$ and $\min\{k\}$, then $k_{y_{max}} = 2^{2(b-1)}$. Now, $\min\{k_y\}$ occurs for $\min\{k_e\}$ and $\max\{k\}$ or vice-versa. Then, $k_{y_{min}} = -2^{(b-2)}(2^b - 2)$. Since $y_n = \mu e_{Q_n} x_n$, we have that $e_{Q_n} = y_n / (\mu x_n) = k_y \Delta / k$. Then,

$$\Pr\{y_n = y|k\Delta, w_n\} = \Pr\{\mu e_{Q_n} x_n = y|k\Delta, w_n\} = \Pr\left\{e_{Q_n} = \frac{k_y \Delta}{k} \middle| k\Delta, w_n\right\} \quad (14)$$

where $\Pr\{e_Q|k\Delta, w_n\}$ can be determined from (11) and (12). Thus, the pdf of y_n can be determined from (14) for k_y running from $k_{y_{min}}$ to $k_{y_{max}}$. However, as y_n results from the multiplication of b -bit numbers, its values will not be integer multiples of Δ . Quantizing y_n to b bits yields y_{Q_n} , whose pdf is then given by

$$f_{y_Q}\{y_Q|k\Delta, w_n\} = \sum_{k_{y_Q}=-2^{(b-1)}}^{k_{y_Q}=2^{(b-1)}-1} \Pr\{y_Q = k_{y_Q} \Delta|k\Delta, w_n\} \delta(y_Q - k_{y_Q} \Delta) \quad (15)$$

with

$$\Pr\{y_Q = k_{y_Q} \Delta|k\Delta, w_n\} = \Pr\{y \geq y_1|k\Delta\}U(y - y_1) - \Pr\{y \geq y_2|k\Delta\}U(y - y_2) \quad (16)$$

where $y_1 = k_{y_Q} \Delta - 0.5\Delta$, $y_2 = k_{y_Q} \Delta + 0.5\Delta$ and $U(\cdot)$ is the unit step function.

Having determined the statistics of y_{Q_n} , we proceed to deter-

mine the conditional pdf of w_{n+1} .

3.4. Conditional pdf of w_{n+1}

To simplify the expressions, we define $\omega_{n+1} = w_n + y_{Q_n}$. Then, $\omega_{n+1} = w_n + Q\{\mu e_{Q_n} x_n\} = w_n + Q\{y_n\}$ and

$$\Pr\{\omega_{n+1} = k_{w1}\Delta|k\Delta, w_n\} = \Pr\{w_n + y_Q = k_{w1}\Delta|k\Delta, w_n\} = \Pr\{y_Q = k_{w1}\Delta - w_n|k\Delta, w_n\} \quad (17)$$

This probability can be determined from (15) and (16). Nevertheless, to determine the statistics of w_{n+1} we must include the saturation effects in (17). Then,

$$f_w\{w_{n+1}|k\Delta, w_n\} = \sum_{k_w=-2^{b-1}}^{k_w=2^{b-1}-1} \Pr\{w_{n+1} = k_w\Delta|k\Delta, w_n\} \delta(w_{n+1} - k_w\Delta) \quad (18)$$

where

$$\Pr\{w_{n+1} = k_w\Delta|k\Delta, w_n\} = \begin{cases} \Pr\{\omega_{n+1} = k_w\Delta|k\Delta, w_n\}, & -1 < w_{n+1} < 1 \\ \sum_{k_{w1}=2^{b-2}}^{k_{w1}=2^b-2} \Pr\{\omega_{n+1} = k_{w1}\Delta|k\Delta, w_n\}, & w_{n+1} = 1 - \Delta \\ \sum_{k_{w1}=-2^{(b-1)}-1}^{k_{w1}=-2^{(b-1)}+1} \Pr\{\omega_{n+1} = k_{w1}\Delta|k\Delta, w_n\}, & w_{n+1} = -1 \end{cases} \quad (19)$$

Eq. (19) allows the determination of the matrix of transition probabilities P_w for the Markov chain w_n . This matrix provides information about the dynamics of the weights and about the convergence of the mean-square estimation error (MSE).

4. CONDITION ON THE STEP SIZE

Once we have determined P_w for the Markov chain, we can determine conditions to be satisfied so that P_w has desirable properties, which translate into an adequate behavior of the LMS algorithm in finite precision. For instance, if w_n is to converge to a unique optimum, P_w matrix must correspond to an aperiodic and, at least, a semi-ergodic Markov chain [10].

A typical problem with quantized adaptive algorithms is the possibility of premature stop or drastic slow-down [8]. To avoid this phenomenon, we must guarantee that $|y_{Q_n}| = |Q\{\mu e_{Q_n} x_n\}| \geq \Delta$ or, equivalently, that $|\mu e_{Q_n} x_n| \geq \Delta/2$. Considering a high signal-to-noise ratio (SNR) (the worst case), $|e_{Q_n}| \geq \Delta$ whenever $w_n \neq \hat{w}$. Then the above condition requires $|\mu x_n| \geq \frac{1}{2}$. The minimum value of μ that satisfies this condition occur for $|x_n| = 1$. Thus, the condition on μ to avoid stopping is

$$\mu \geq \frac{1}{2} \quad (20)$$

We use this limit in the following example.

5. PERFORMANCE ESTIMATION

In this section we illustrate the use of the theoretical model to determine the finite precision LMS adaptive filter behavior.

Consider an example with $\text{SNR} = 20\text{dB}$, $\mu = 1$ (thus, $\mu \geq 1/2$), $b = 3$ bits (8 quantization levels), $\hat{w} = 0.75$, $\sigma_z^2 = 0.0034$ and $w_0 = -1$. Using (18) and (19), we determine the transition probabilities for w_n . The matrix P_w^∞ (steady-state) is given by:

$$w_n/w_{n+1} \rightarrow \begin{bmatrix} -1 & -0.75 & -0.5 & -0.25 & 0.00 & 0.25 & 0.50 & 0.75 \end{bmatrix}$$

$$P_w^\infty = \begin{bmatrix} 0.00 & 0.00 & 0.00 & 0.00 & 0.00 & 0.00 & 0.31 & 0.69 \\ 0.00 & 0.00 & 0.00 & 0.00 & 0.00 & 0.00 & 0.31 & 0.69 \\ 0.00 & 0.00 & 0.00 & 0.00 & 0.00 & 0.00 & 0.31 & 0.69 \\ 0.00 & 0.00 & 0.00 & 0.00 & 0.00 & 0.00 & 0.31 & 0.69 \\ 0.00 & 0.00 & 0.00 & 0.00 & 0.00 & 0.00 & 0.31 & 0.69 \\ 0.00 & 0.00 & 0.00 & 0.00 & 0.00 & 0.00 & 0.31 & 0.69 \\ 0.00 & 0.00 & 0.00 & 0.00 & 0.00 & 0.00 & 0.31 & 0.69 \\ 0.00 & 0.00 & 0.00 & 0.00 & 0.00 & 0.00 & 0.31 & 0.69 \end{bmatrix}$$

This matrix corresponds to a semi-ergodic Markov chain [10]. It shows that $E[w_n] = 0.5 \times 0.31 + 0.75 \times 0.69 = 0.6725$ in steady-state. The steady-state coefficient misadjustment is then -0.1% . Using (11) and (12), it is possible to determine the probability of the quantized error e_{Q_n} for each state of w_n . Therefore, we can evaluate the MSE at the n -th iteration from the knowledge of P_w^n . Table 1 shows the MSE at iteration n for each possible value of w_n .

Table 1. MSE for each state of w_n

w_n	MSE
-1	0.5446
-0.75	0.5445
-0.5	0.4781
-0.25	0.3876
0	0.1966
0.25	0.0751
0.5	0.0204
0.75	0.0126

Then, to determine the MSE at iteration n we multiply the MSE vector by the row of P_w^n corresponding to the initial weight value w_0 . For this example $w_0 = -1$. Thus, the first line of P_w^n must be considered. In steady-state, we multiply the first row of P_w^∞ by the MSE vector in Table 1, yielding $\lim_{n \rightarrow \infty} E[e_n^2] = 0.015$ or -18.24dB . Fig. 3 shows the MSE obtained from Monte Carlo simulations (100 runs) as the smooth line. The dots correspond to estimations evaluated using the theoretical model. The matrices P_w^n used for the transient period are not shown for space limitations. Note that there is excellent agreement between simulation and theory.

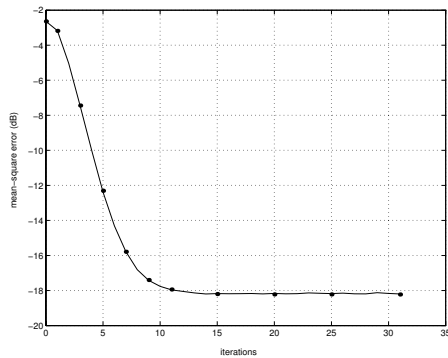

Fig. 3. Monte Carlo simulations of eq.(1) (-) versus the MSE obtained from theory (\cdot).

6. CONCLUSIONS

This paper presented a new model for the behavior of the LMS algorithm when implemented in finite precision. The adaptive filter coefficients were modeled as a Markov chain and the matrix of transition probabilities of the chain was determined for the one-dimensional case. Linearizations used in other models available in the literature are eliminated. The new model includes saturation effects in the quantization process. The theoretical results can be used to determine the transient and steady-state behaviors of the adaptive weights and MSE. Monte Carlo simulation results illustrate the quality of the proposed model.

7. ACKNOWLEDGMENTS

The authors thank the University of Antofagasta, Chile, Magister scholarship: MECESUP ANT-102 project. This paper was financed in part by CNPq, under grants Nos. 308095/2003-0 and 472762/2003-6, and by the FAPESP under grant N° 2004/15114-2.

8. REFERENCES

- [1] S. Haykin, *Adaptive Filter Theory*, Fourth edition, Prentice-Hall, Inc., New Jersey, 2002
- [2] D.G. Manolakis, V.K. Ingle and S.M. Kogon, *Statistical and adaptive signal processing: spectral estimation, signal modeling, adaptive filtering and array processing*, McGraw-Hill, USA, 2000.
- [3] C. Caraiscos and B. Liu, *A roundoff error analysis of LMS adaptive algorithm*, IEEE Trans. Acoust., Speech, Signal Processing, vol. ASSP-32, no. 1, pp. 34-41, Feb. 1984.
- [4] S.T. Alexander, *Transient weight misadjustment properties for the finite precision LMS algorithm*, IEEE Trans. Acoust., Speech, Signal Processing, vol. ASSP-35, no. 9, pp. 1250-1258, Sept. 1984.
- [5] J.M. Cioffi, *Limited precision effects in adaptive filtering*, IEEE Trans. on circuits and systems, vol. CAS-34, no. 7, pp. 821-833, July 1987.
- [6] J.C.M. Bermudez and N.J. Bershad, *A nonlinear analytical model for the quantized LMS algorithm - The arbitrary step size case*, IEEE Trans. Signal Processing, vol. 44, no. 5, pp. 1175-1183, May 1996.
- [7] J.C.M. Bermudez and N.J. Bershad, *Transient and tracking performance analysis of the quantized LMS algorithm for time-varying system identification*, IEEE Trans. Signal Processing, vol. 44, no. 8, pp. 1990-1997, August 1996.
- [8] J.C.M. Bermudez and N.J. Bershad, *New insights on the transient and steady-state behavior of the quantized LMS algorithm*, IEEE Trans. Signal Processing, vol. 44, no. 10, pp. 2623-2625, October 1996.
- [9] J.C.M. Bermudez and N.J. Bershad, *A nonlinear analytical model for the quantized LMS algorithm - The power-of-two step size case*, IEEE Trans. Signal Processing, vol. 44, no. 11, pp. 2895-2900, November 1996.
- [10] J.R. Norris, *Markov Chains*, Cambridge University Press, Cambridge, UK, 1997.